

XP6	XP2	XP1	Разрешение
1 и 2	2 и 3	2 и 3	384x256
1 и 2	2 и 3	1 и 2	384x256
-	2 и 3	1 и 2	480x256
1 и 2	1 и 2	2 и 3	384x256
-	1 и 2	2 и 3	512x256

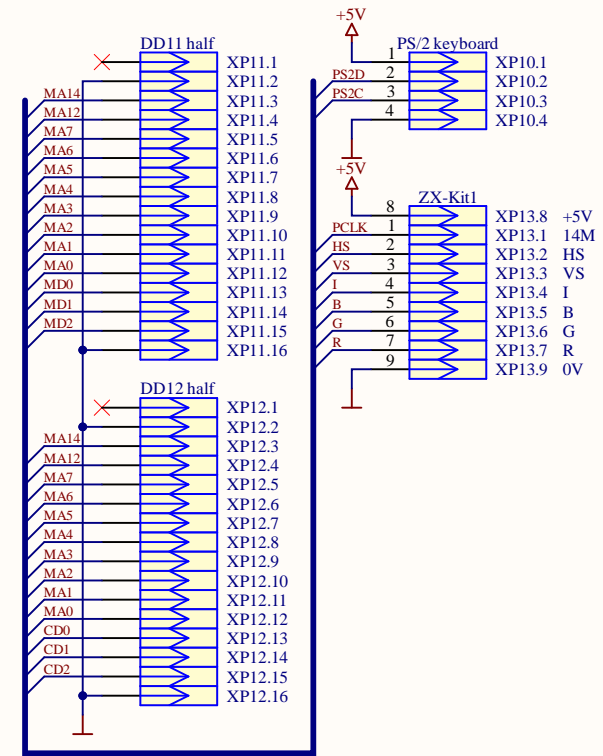

Title Сябр. Основная плата. Дополнения.			Autor: SYR-ALEX		
Size: A4	Number: 2	Revision: V2.6	Drawn by: Fifan		
Date: 25.09.2023	Time: 18:40:30	Sheet 2 of 2			
File: C:\Users\Vitaly\Documents\Altium\AD22\Projects\Сябр2\Дополнения.SchDoc					

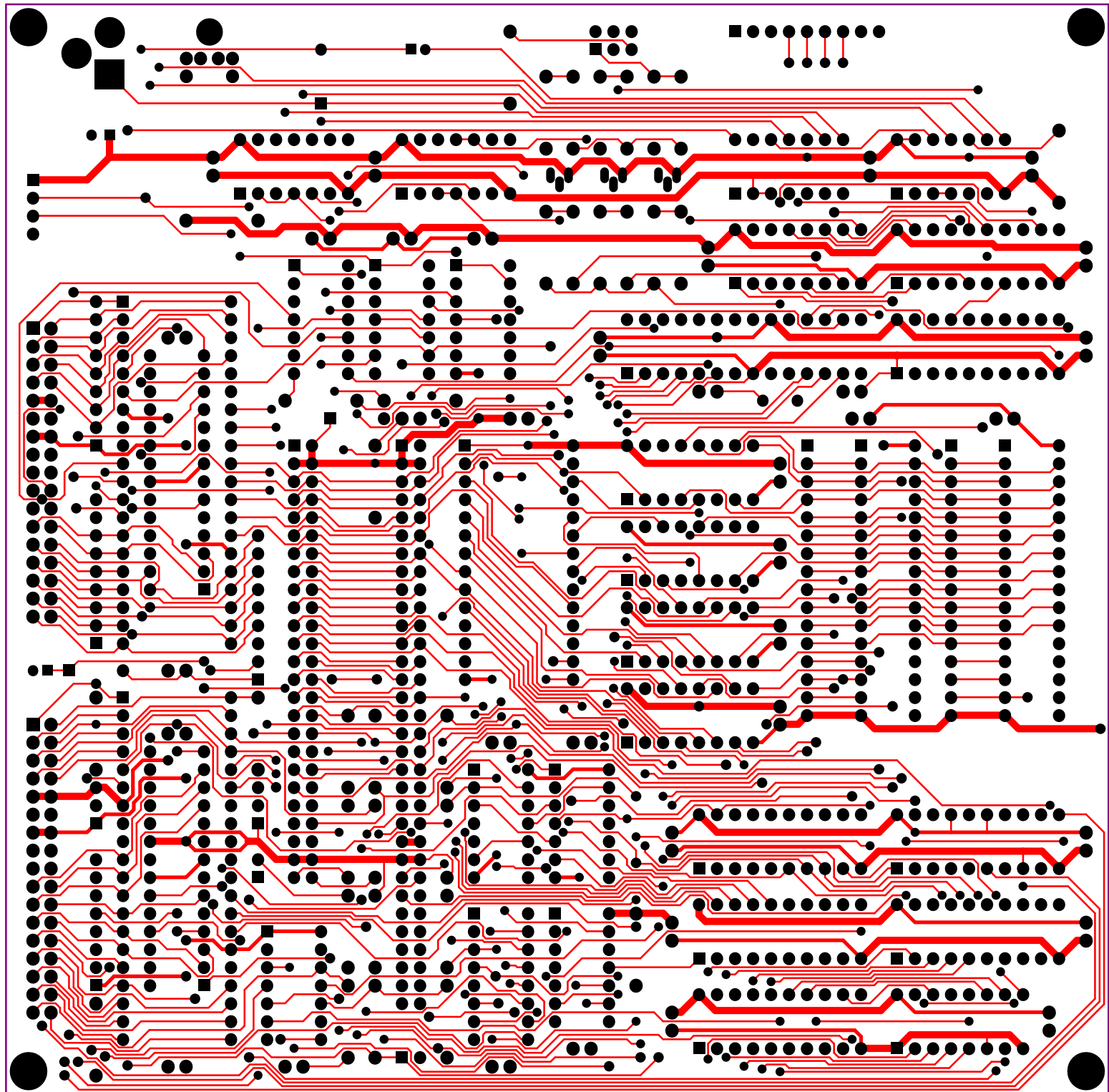

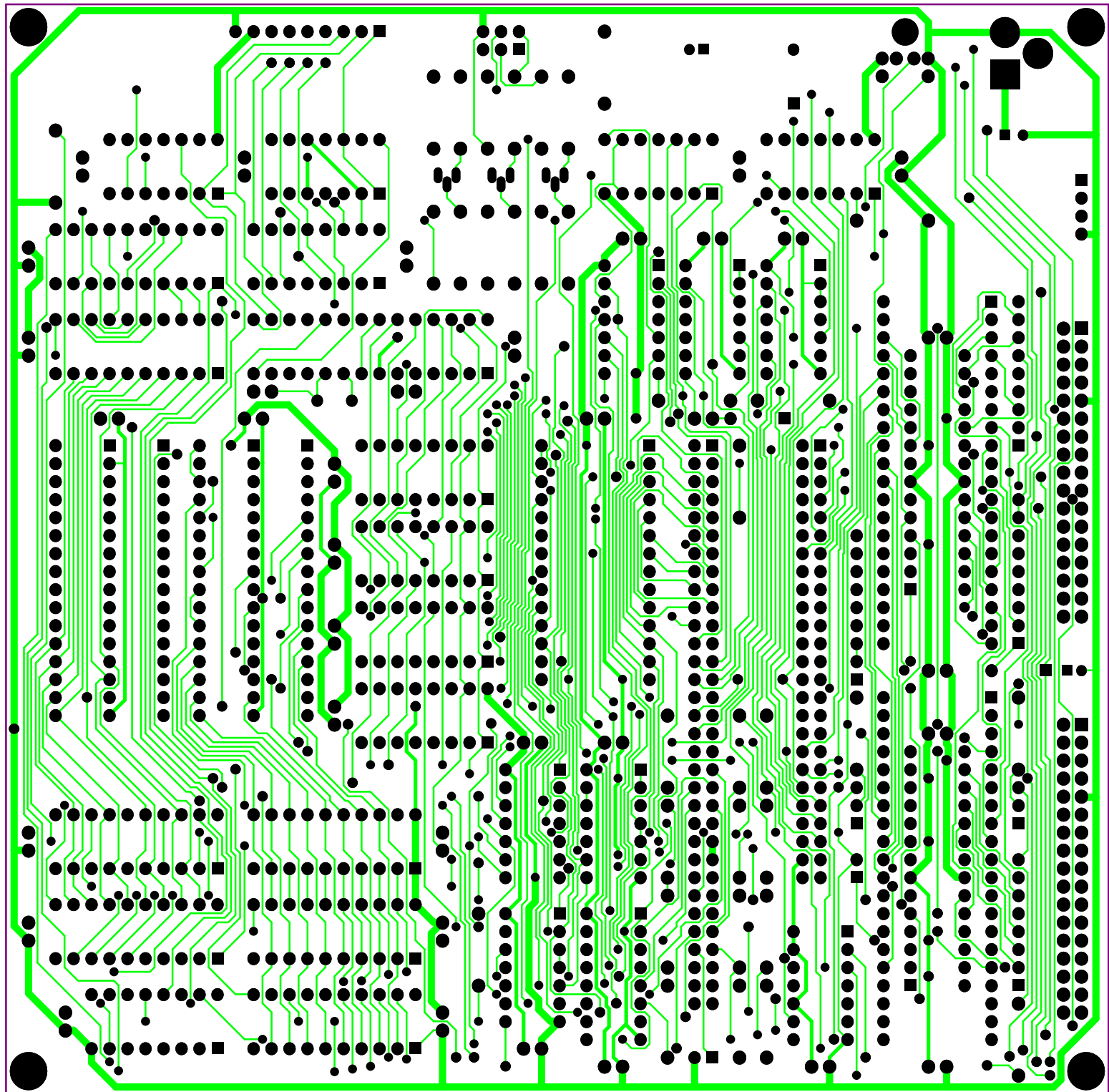

Autor: SYR-ALEX
Design: Fifan

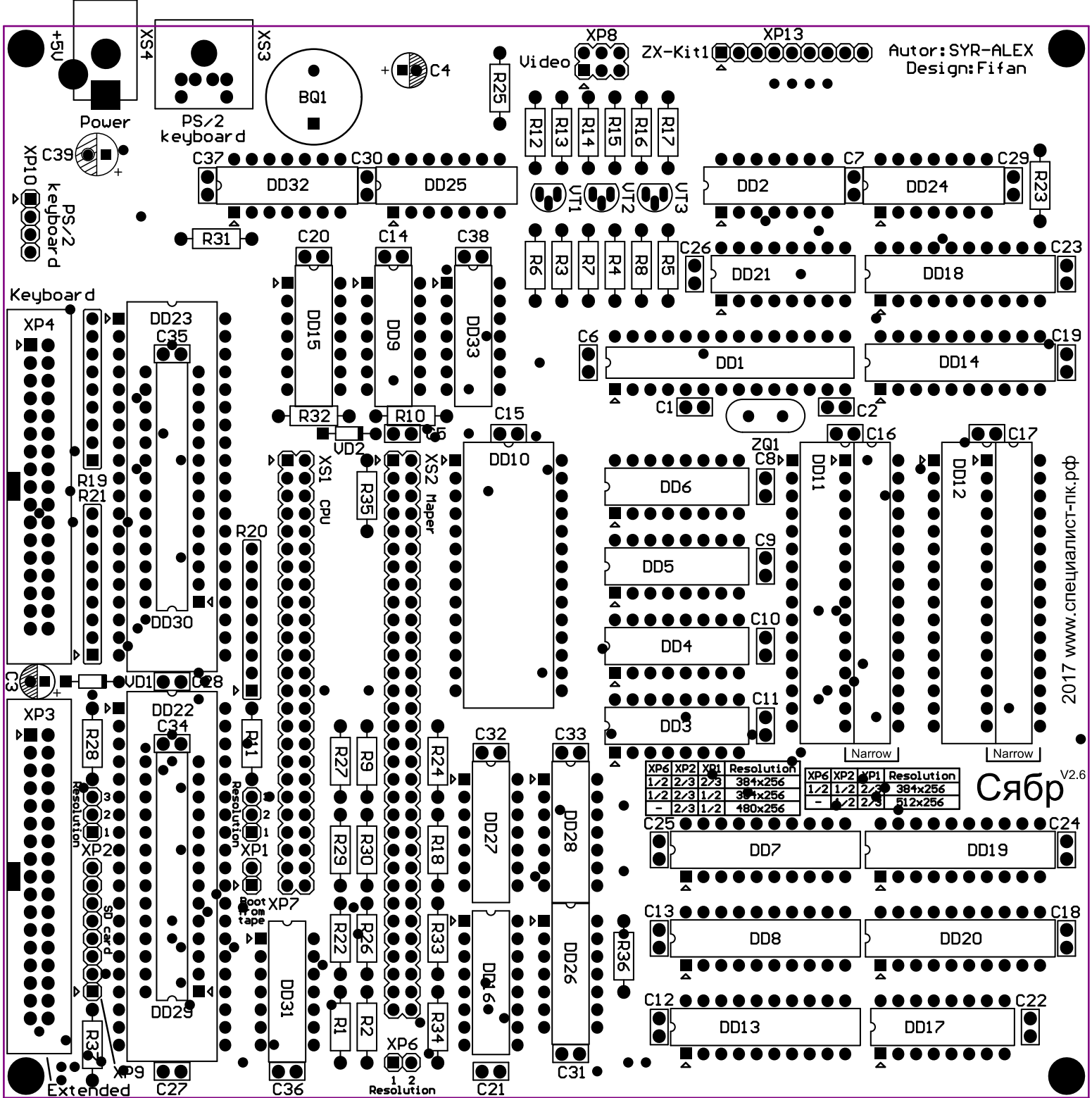

XP6	XP2	XP1	Resolution	XP6	XP2	XP1	Resolution
1/2	2/3	2/3	384x256	1/2	1/2	2/3	384x256
1/2	2/3	1/2	384x256	-	1/2	2/3	512x256
-	2/3	1/2	480x256				

Сябр V2.6

2017 www.специалист-пк.рф

Extended

Resolution

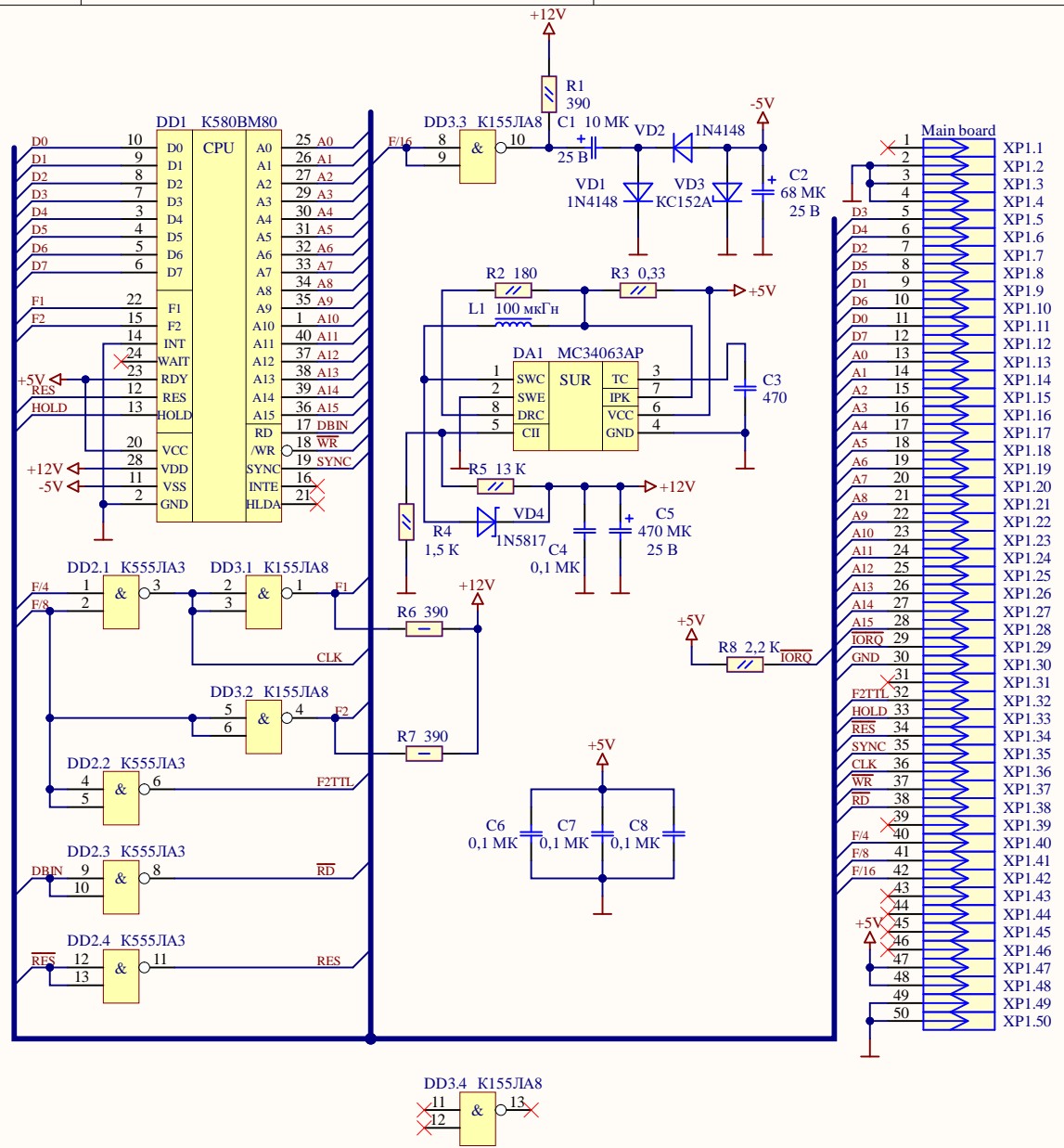

Title Сябр V2.6. Микропроцессор 8080.			Autor: SYR-ALEX	
Size: A4	Number:*	Revision:3		
Date: 10.12.2023	Time: 11:08:01	Sheet 1 of 1		
File: C:\Users\Vitaly\Documents\Altium\AD22\Projects\CPU_8080\Sheet1.SchDoc				



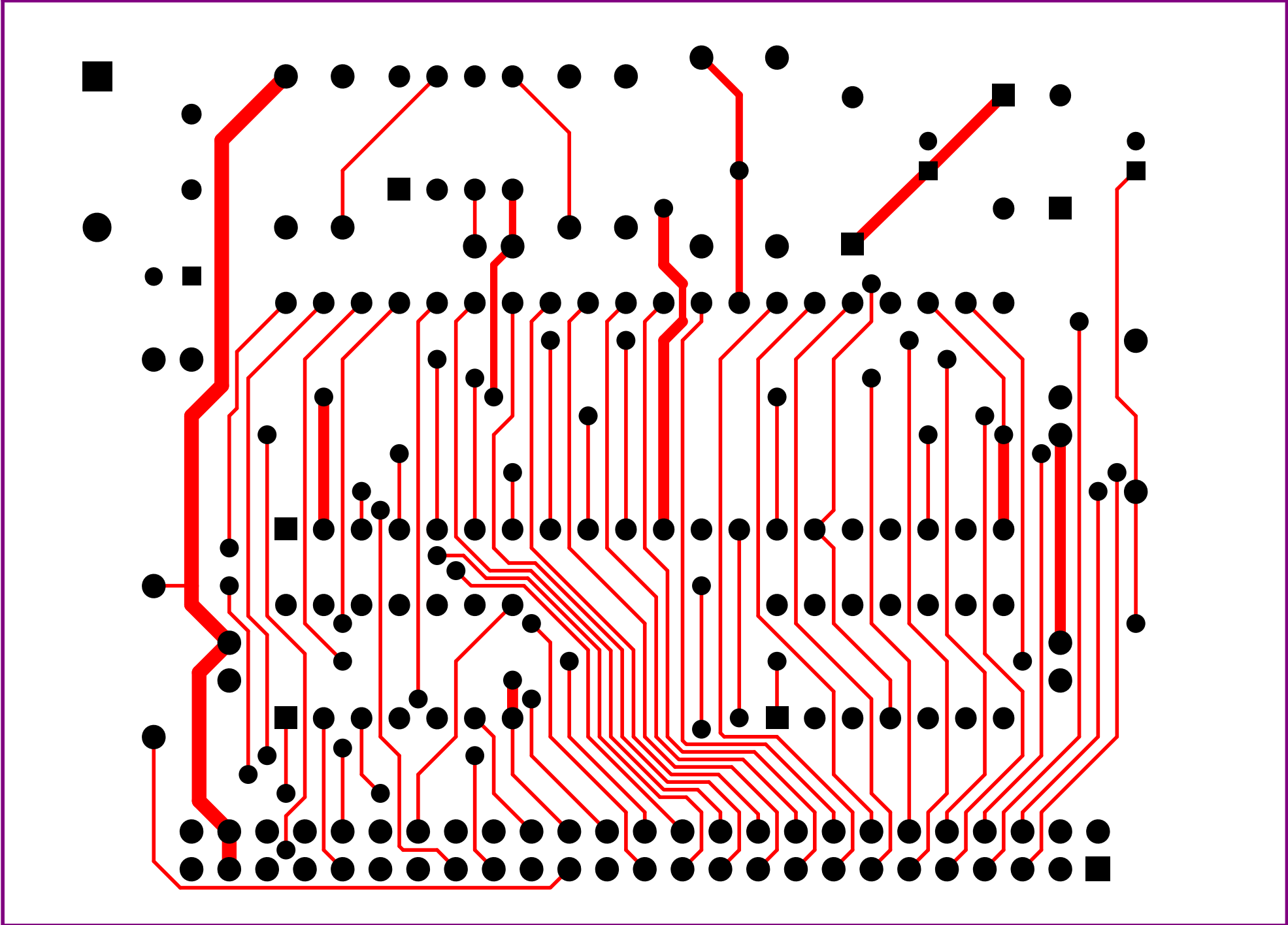

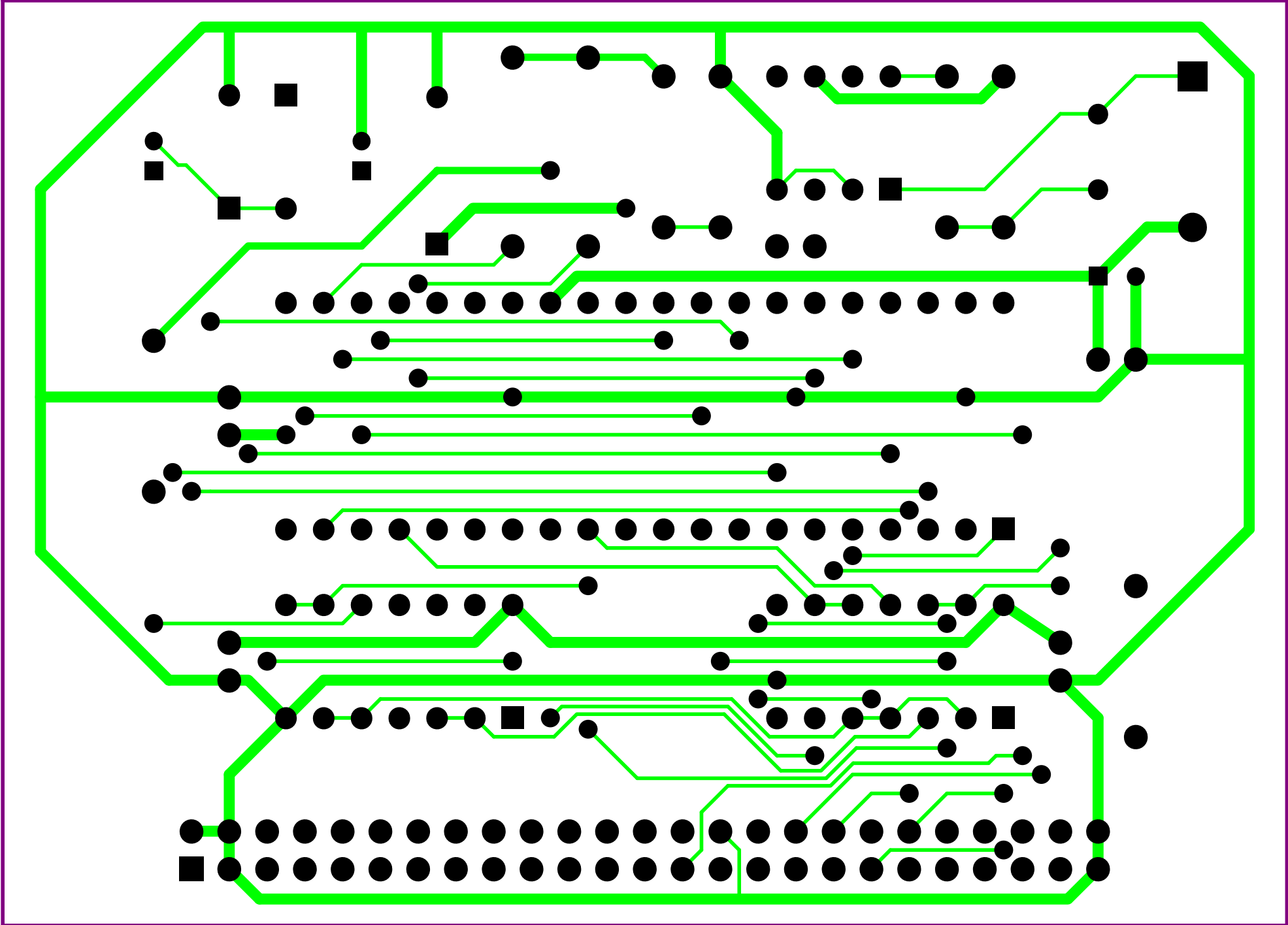

Autor: SYR-ALEX Design: Fifan

Main board

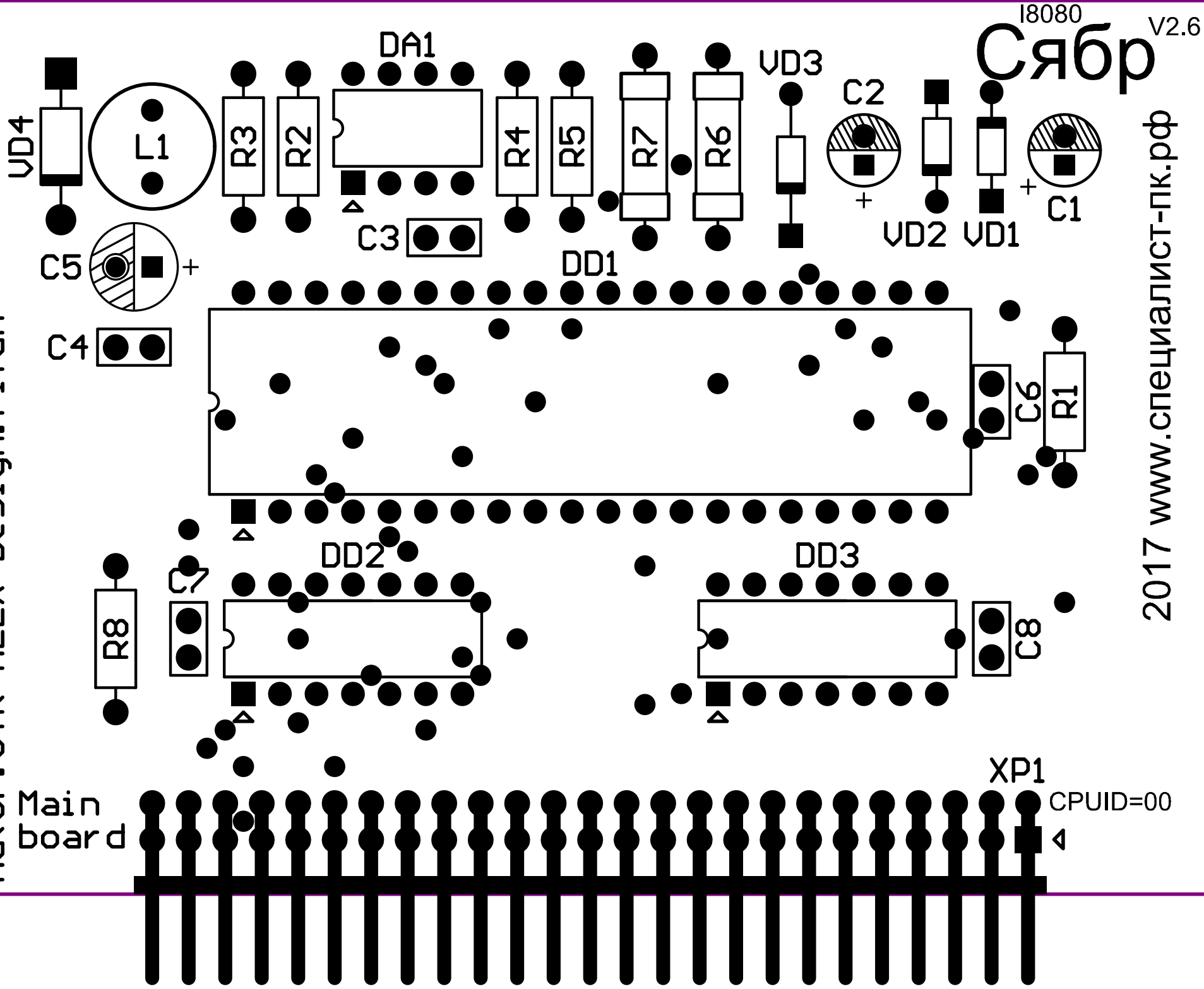

И8080
Сябр V2.6

2017 www.специалист-пк.рф

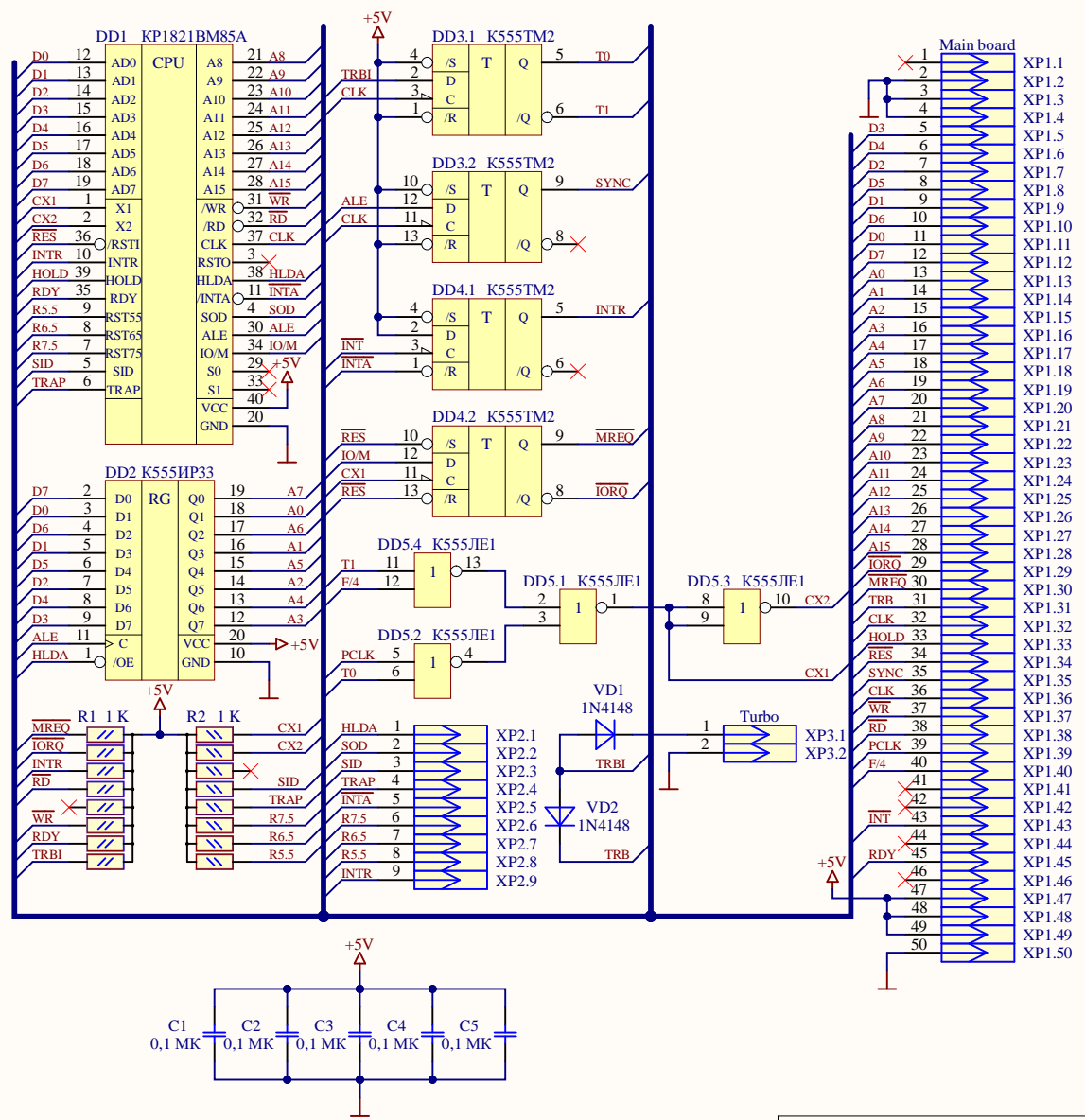

Title Сябр V2.6. Микропроцессор 8085.			Autor: SYR-ALEX		
Size: A4	Number: 3	Revision: 3	Drawn by: Fyfan		
Date: 10.12.2023	Time: 15:47:35	Sheet 1 of 1			
File: C:\Users\Vitaly\Documents\Altium\AD22\Projects\CPU_8085\Sheet1.SchDoc					

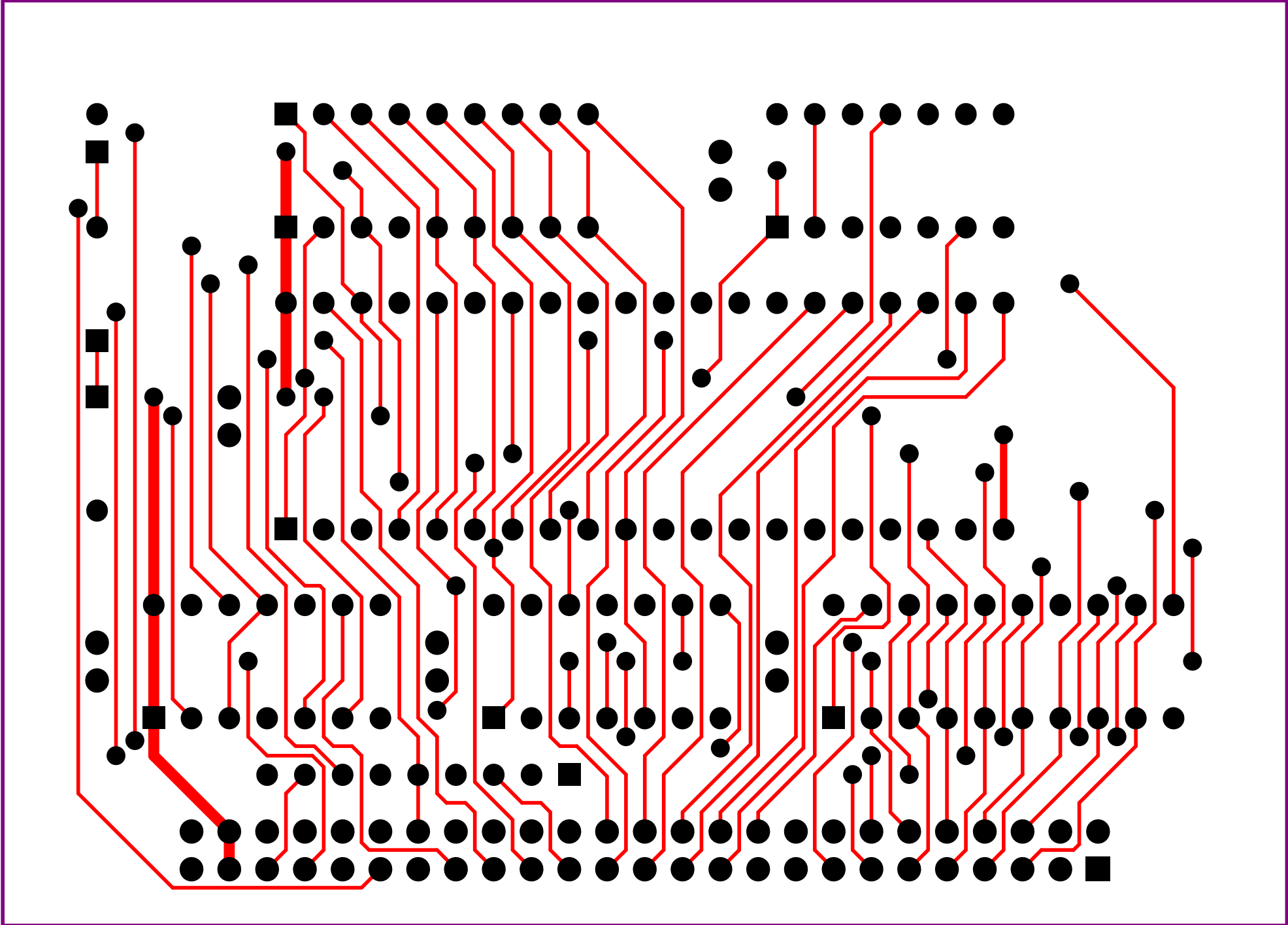

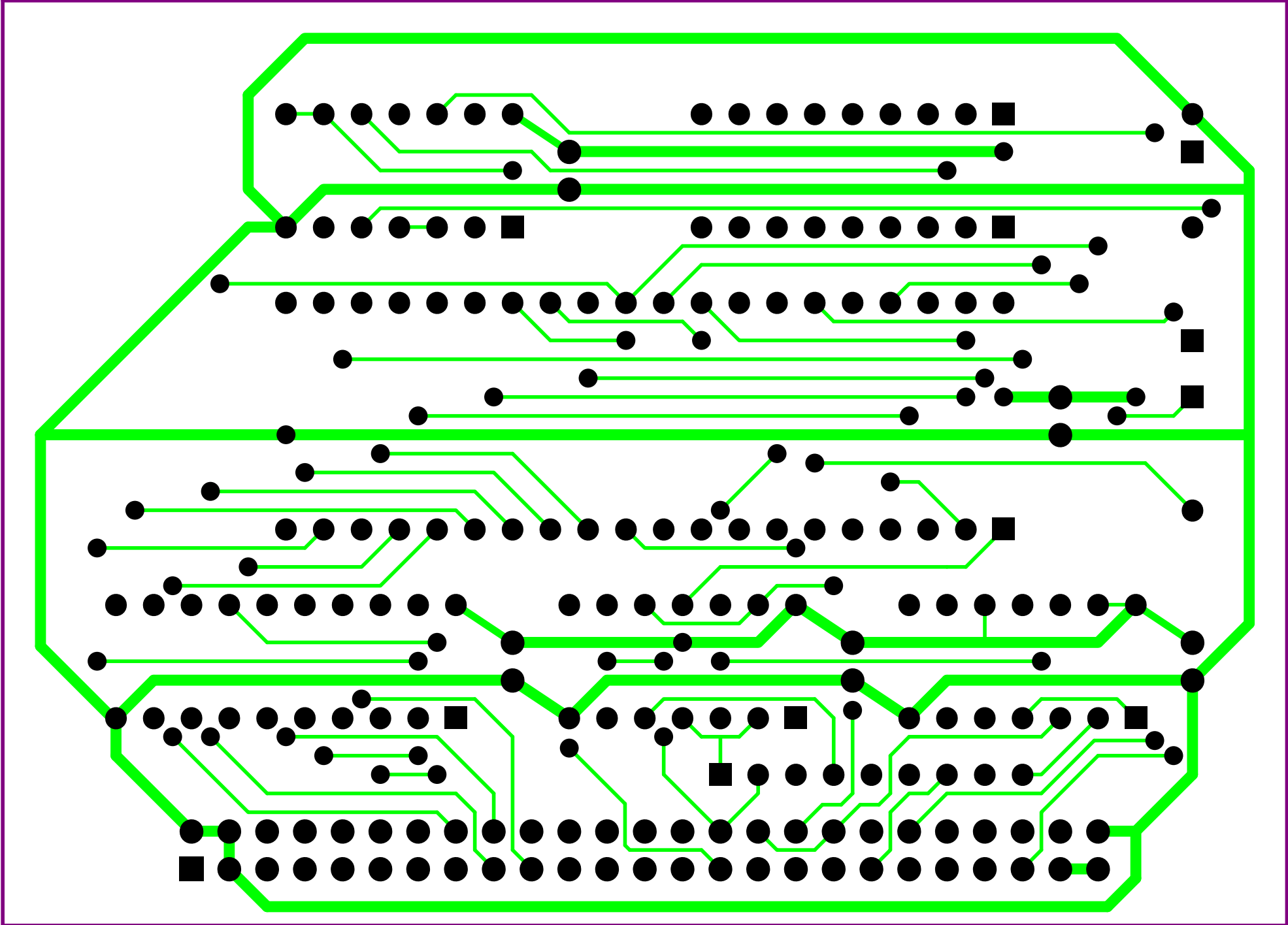

Autor: SYR-ALEX Design: Fifan

Main board

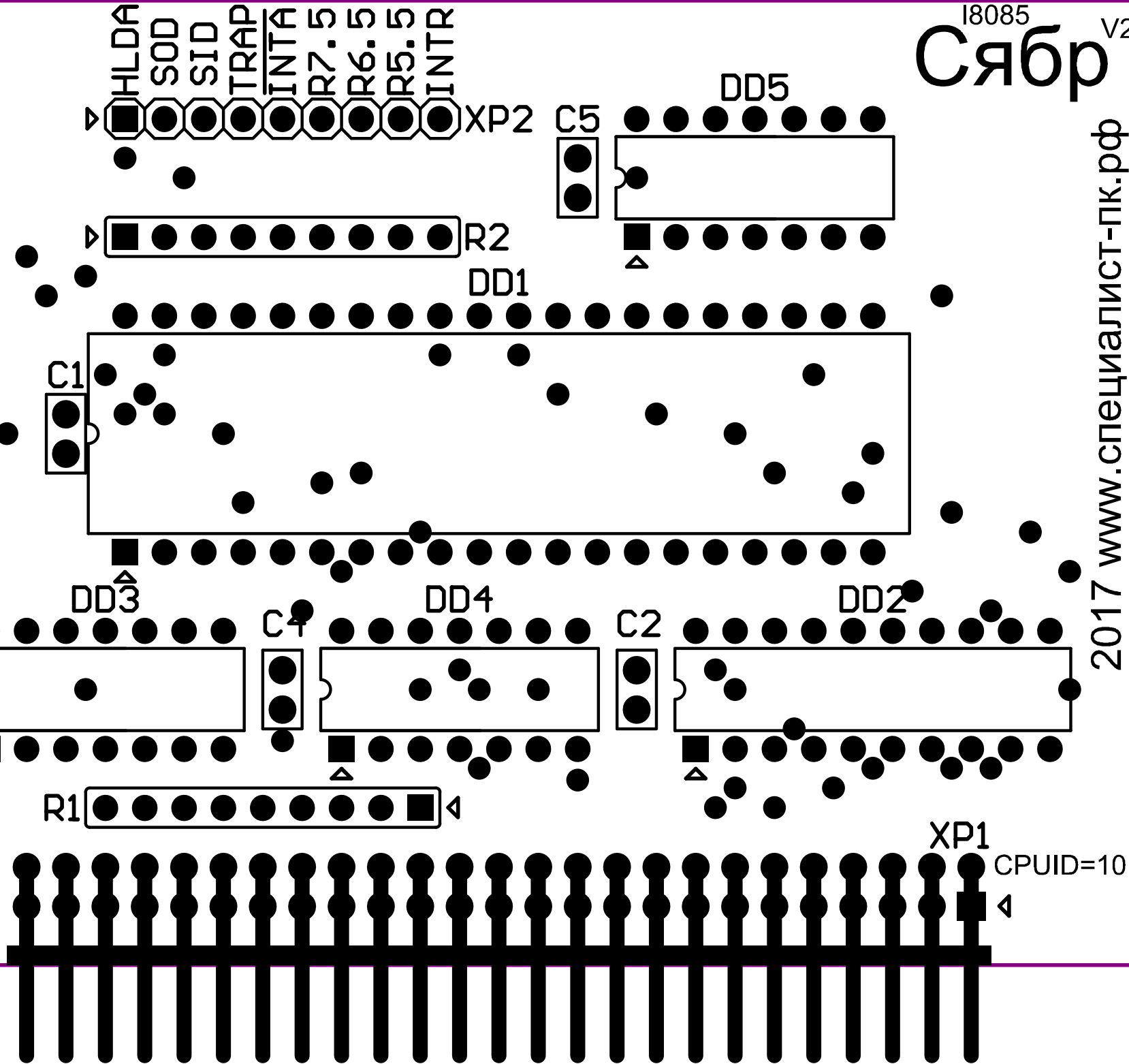
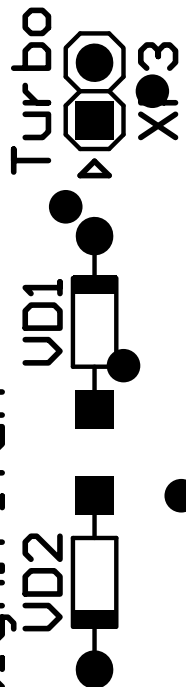

18085
Сябр V2.6

2017 www.специалист-пк.рф

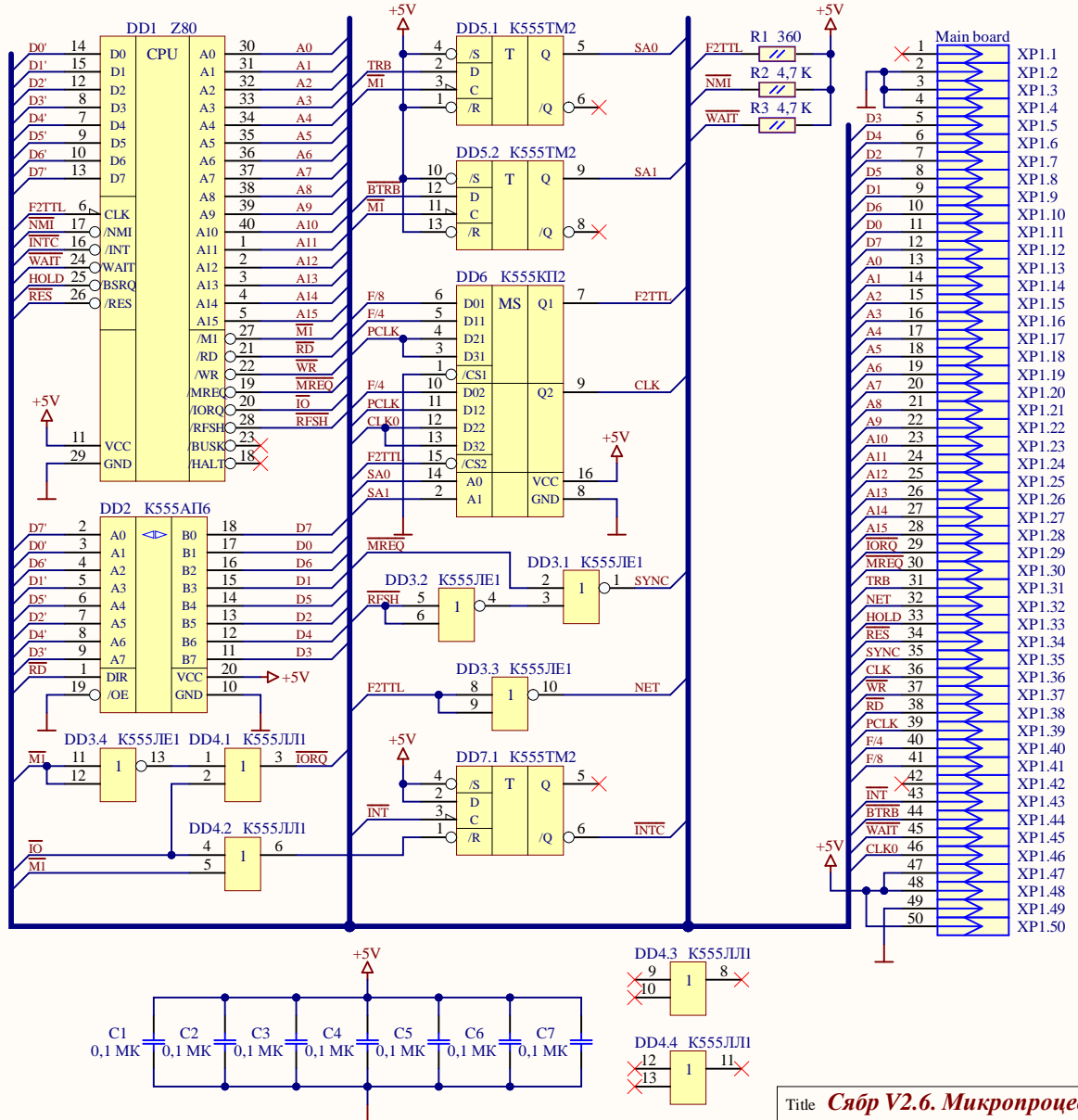

Title **Сябр V2.6. Микропроцессор Z80.**

Autor: SYR-ALEX



Size: A4

Number: 4

Revision: 3

Drawn by: Fiban

Date: 10.12.2023

Time: 15:45:26

Sheet 1 of 1

File: C:\Users\Vitaly\Documents\Altium\AD22\Projects\CPU_Z80\Sheet1.SchDoc

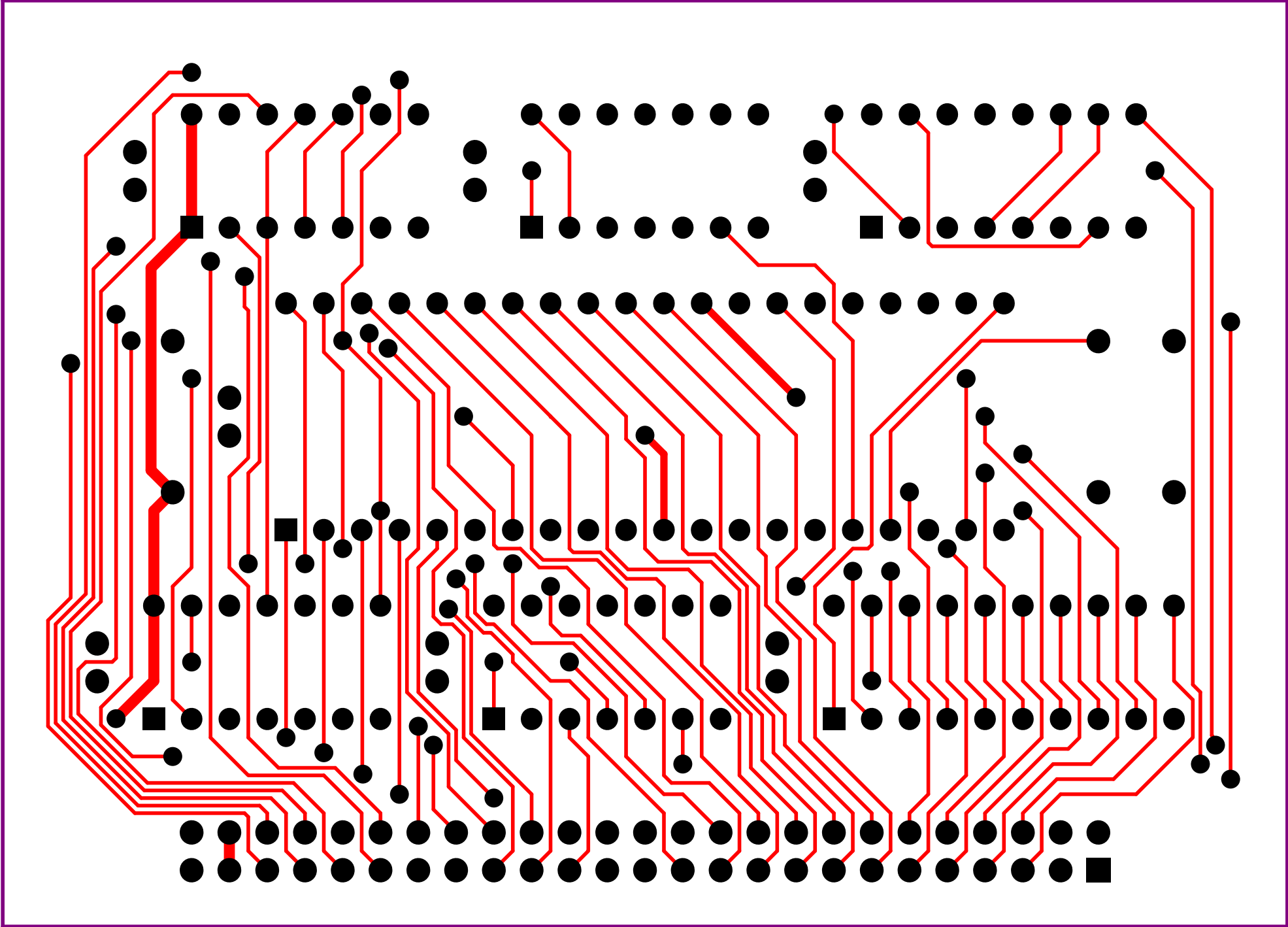

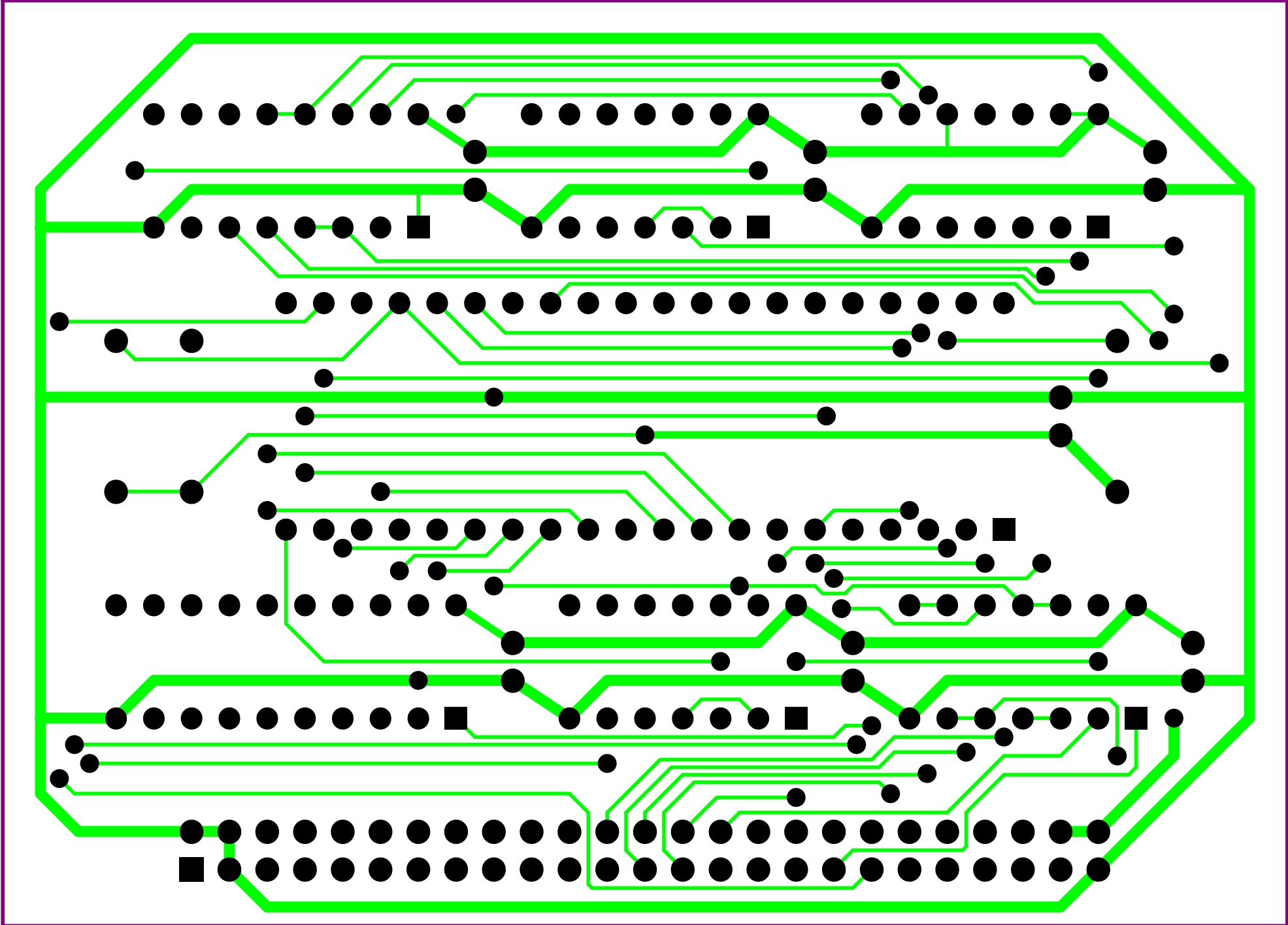

Сябр

2017 www.СПЕЦИАЛИСТ-ПК.рф

Autor: SYR-ALEX Design: Fifan

Main board

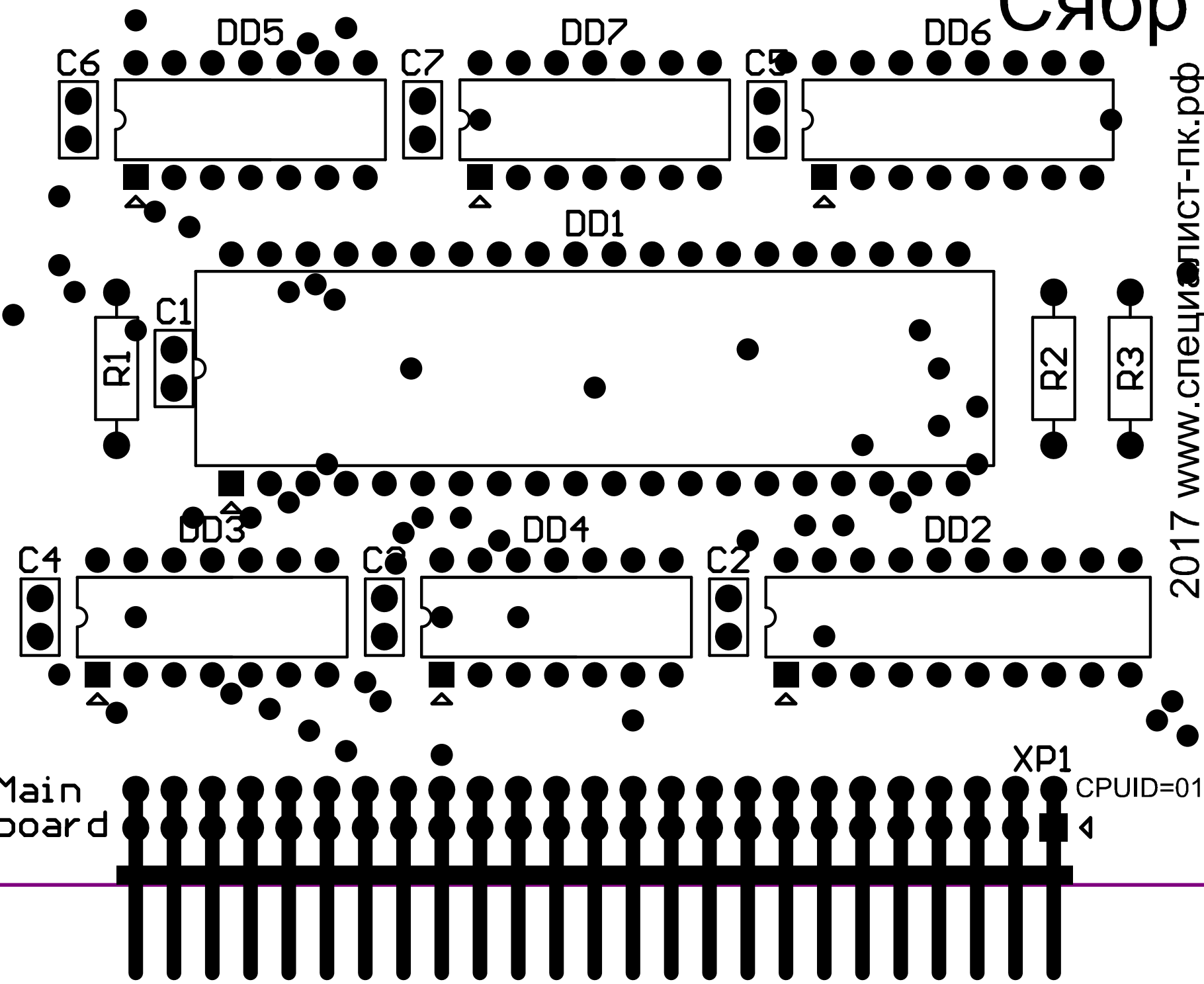

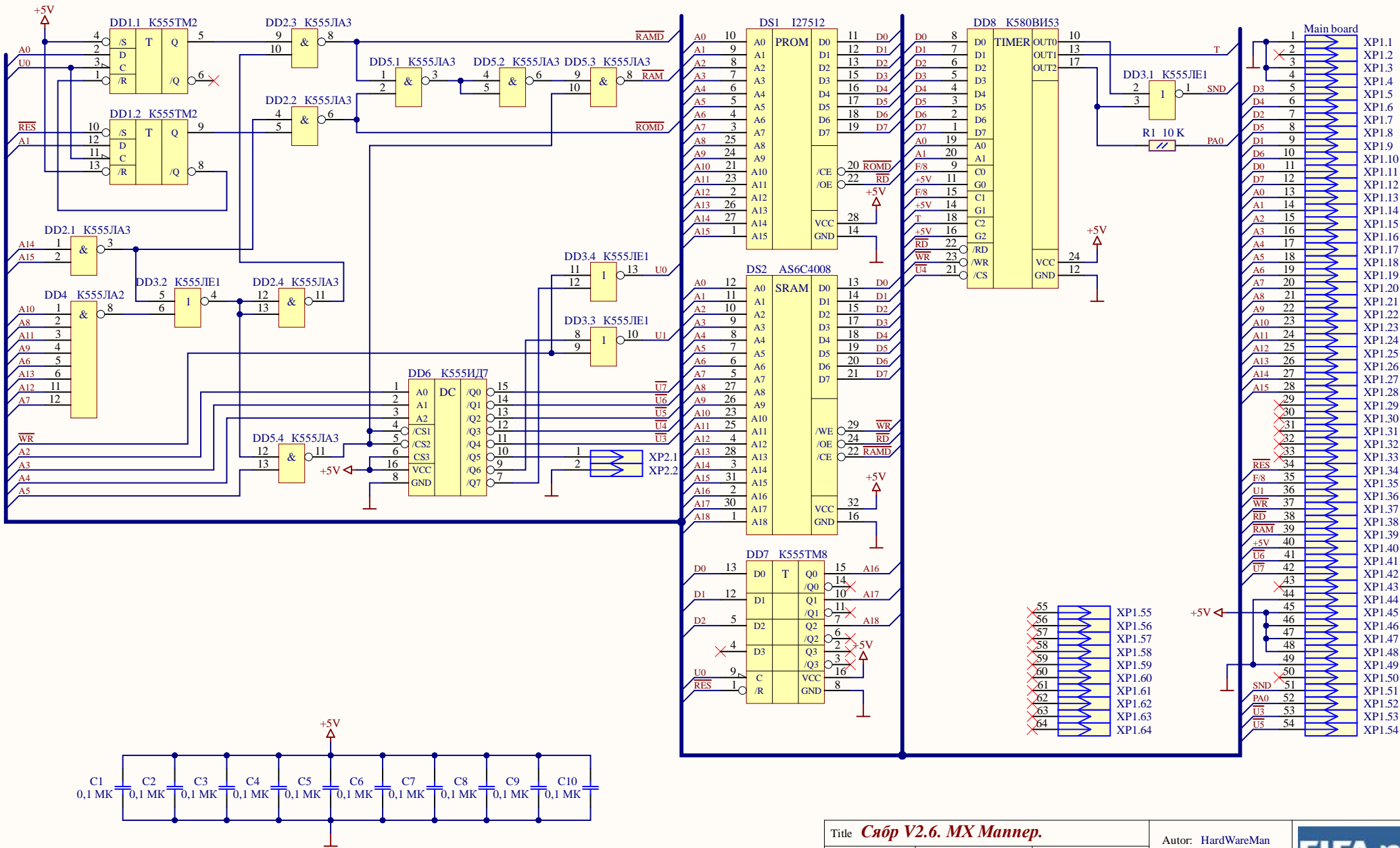

Title Схѣм V2.6. MX Mapper.			Autor: HardWareMan		
Size: A4	Number:4	Revision:3	Drawn by: Fifyan		
Date: 10.12.2023	Time: 16:39:57	Sheet 1 of 1			
File: C:\Users\Vitaly\Documents\Altium\AD22\Projects\Mapper_MX\Sheet1.SchDoc					

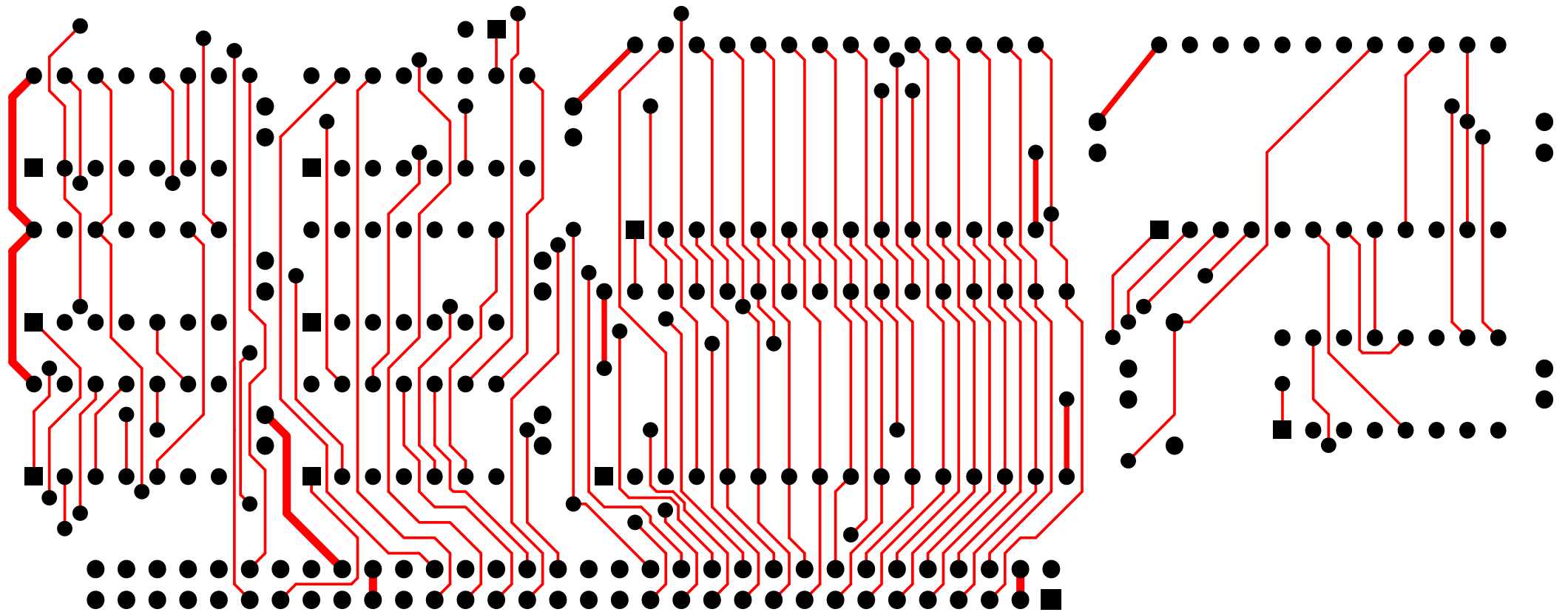

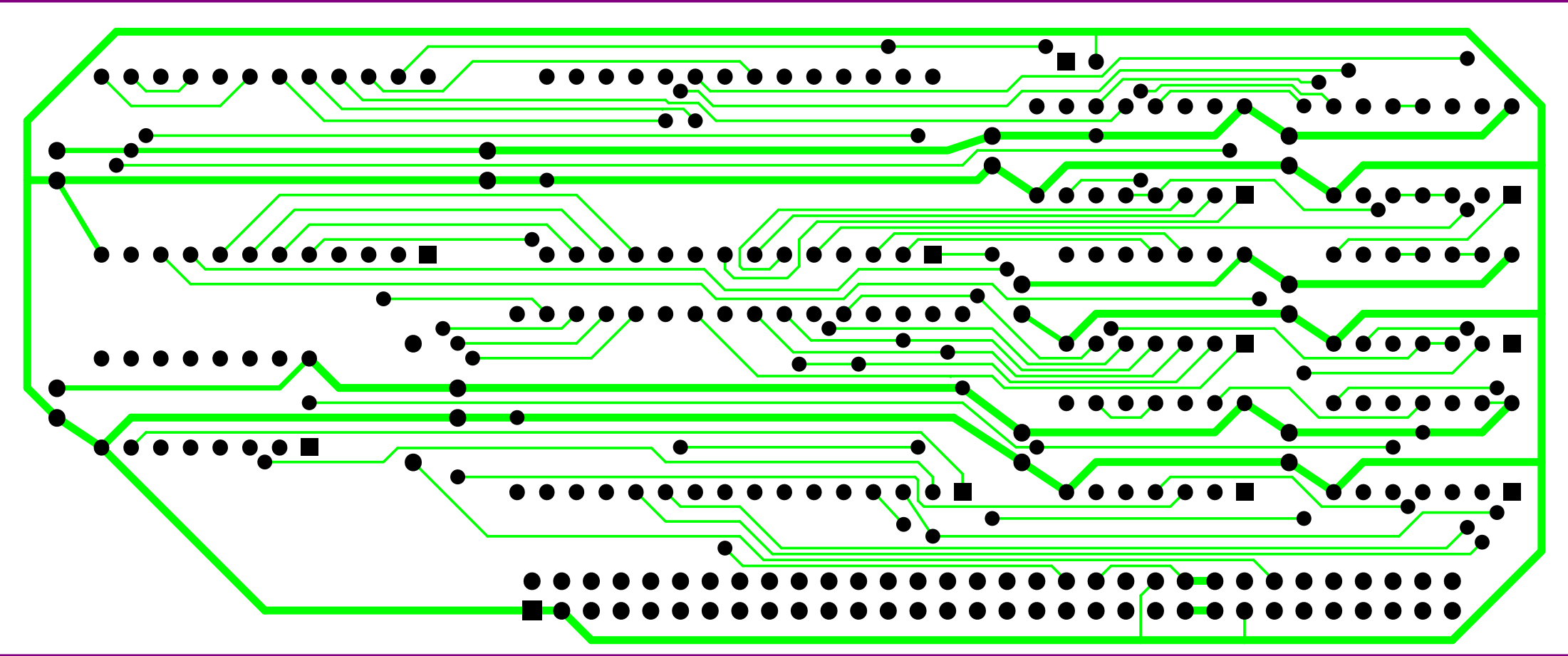

Main board

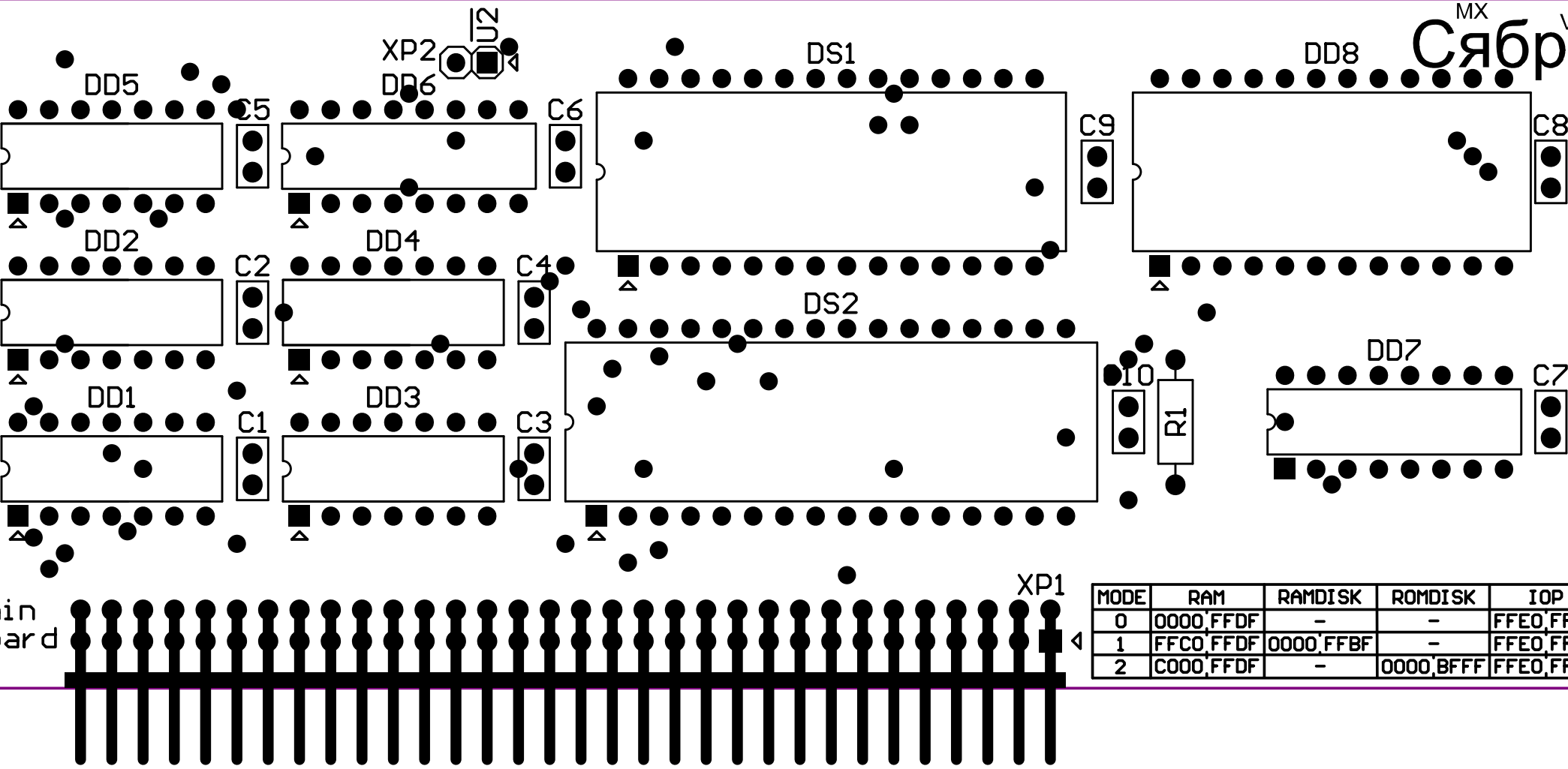

Сябр V2.6 MX

MODE	RAM	RAMDISK	ROMDISK	IOP
0	0000,FFDF	-	-	FFEO,FFFF
1	FFC0,FFDF	0000,FFBF	-	FFEO,FFFF
2	C000,FFDF	-	0000,BFFF	FFEO,FFFF

A

A

B

B

C

C

D

D

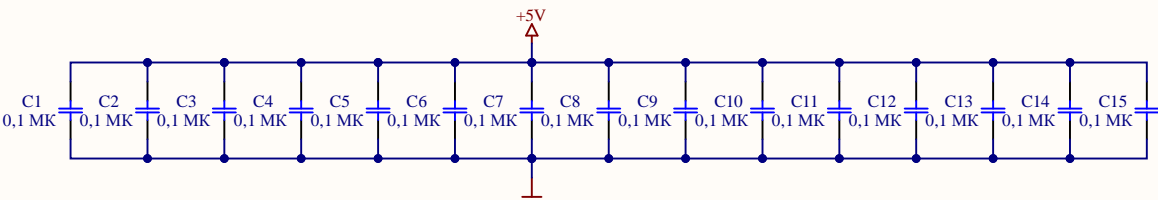
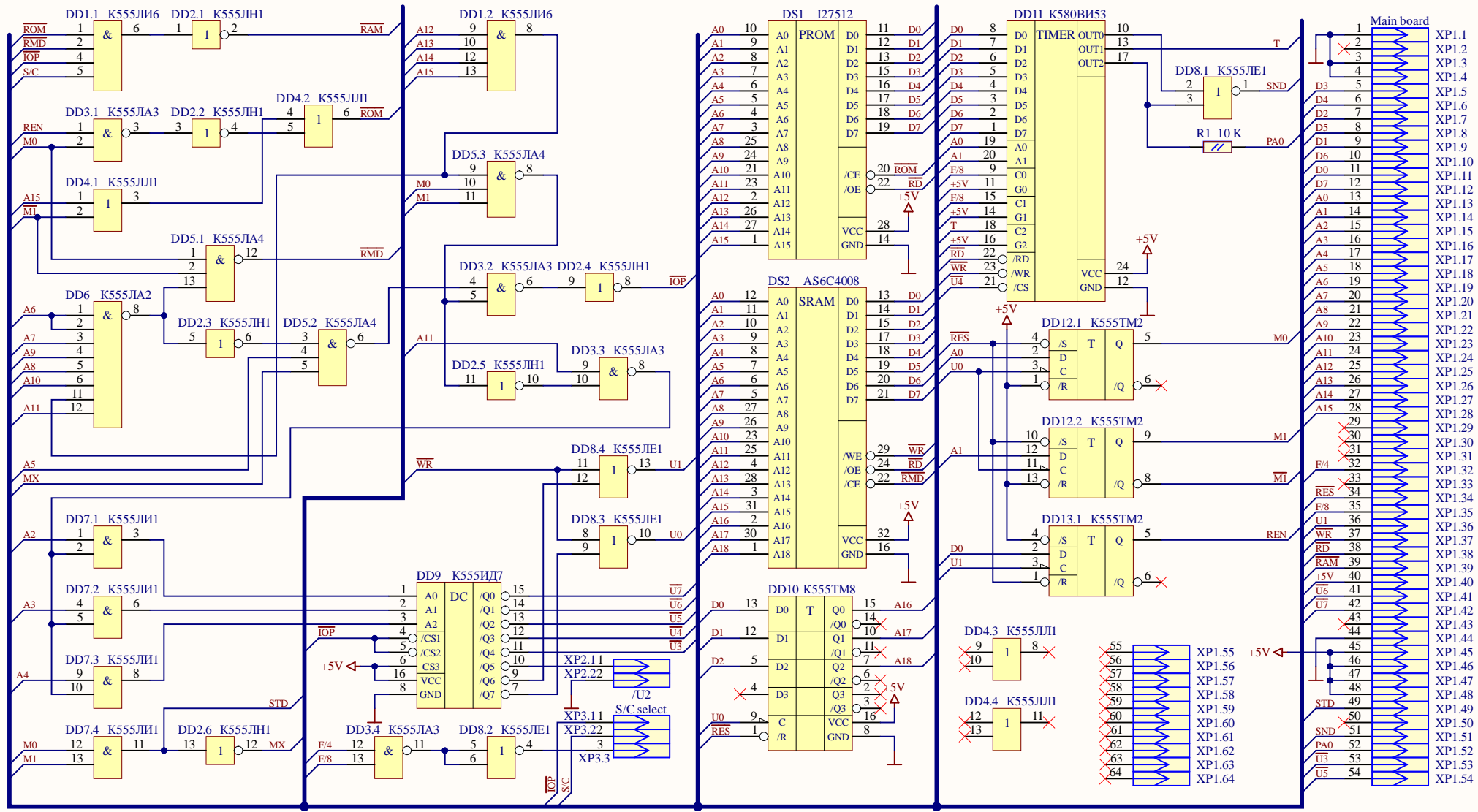

Title Сябр V2.6. MX2 Маннер.			Autor: HardWareMan	
Size: A4	Number: 4	Revision: 3	Drawn by: Fifan	
Date: 10.12.2023	Time: 16:59:36	Sheet 1 of 1		
File: C:\Users\Vitaly\Documents\Altium\AD22\Projects\Mapper_MX2\Sheet1.SchDoc				

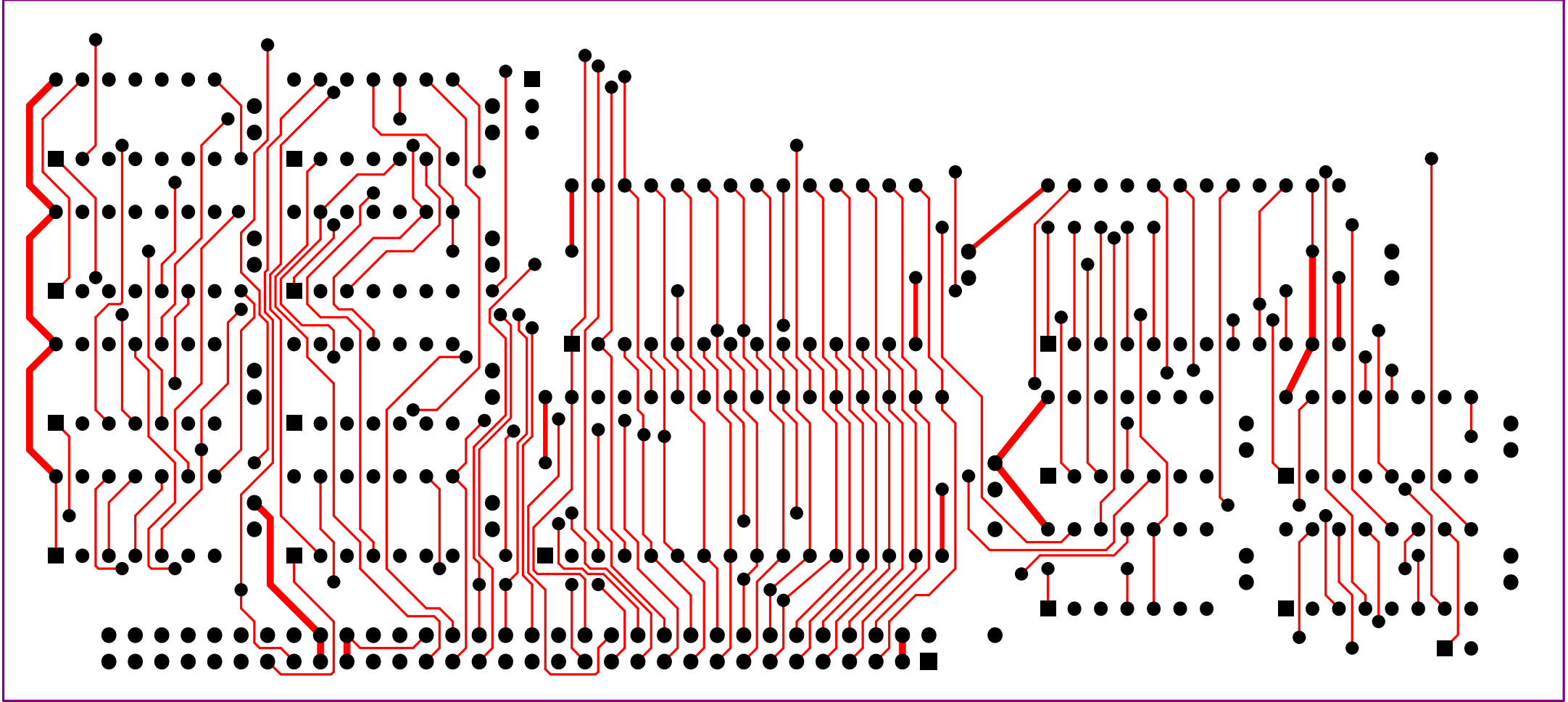

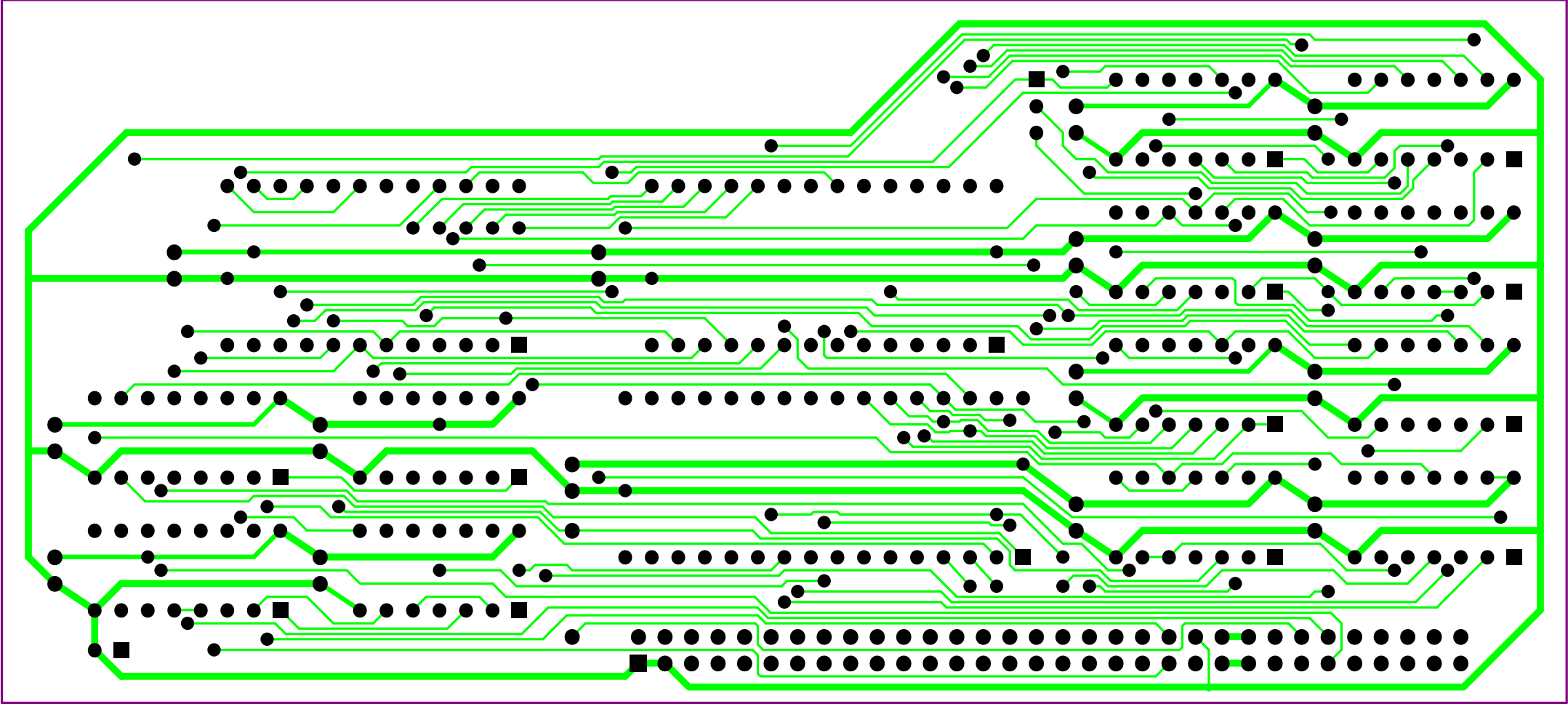

MODE	RAM	RAMDISK	ROMDISK	IOP
0	0000,FFDF	-	-	FFE0,FFFF
1	FFC0,FFDF	0000,FFBF	-	FFE0,FFFF
2	C000,FFDF	-	0000,BFFF	FFE0,FFFF
3	8000,EFFF	-	0000,7FFF	F000,FFFF

